

brembana speed

3/4 axes CNC machines



CMS is part of SCM Group, a technological world leader in processing a wide range of materials: wood, plastic, glass, stone, metal and composites. The Group companies, operating throughout the world, are reliable partners of leading manufacturing industries in various market sectors, including the furniture, construction, automotive, aerospace, ship-building and plastic processing industries. SCM Group coordinates, supports and develops a system of industrial excellence in 3 large highly specialized production centers employing more than 4,000 workers and operating in all 5 continents. SCM Group: the most advanced skills and know-how in the fields of industrial machinery and components.

CMS SpA manufactures machinery and systems for the machining of composite materials, carbon fibre, aluminium, light alloys, plastic, glass, stone and metals. It was established in 1969 by Mr Pietro Aceti with the aim of offering customized and state-of-the-art solutions, based on the in-depth understanding of the customer's production needs. Significant technological innovations, originating from substantial investments in research and development and take-overs of premium companies, have enabled constant growth in the various sectors of reference.



CMS Stone Technology realizes avant-garde solutions for the working of marble, natural stones and composite stones. Under the brand name Brembana Macchine, CMS Stone Technology was in the 80's the first manufacturer of a stone machining center, thanks to an idea of its founder Mr Pietro Aceti. **CMS Stone Technology** has always been a reliable technological partner in designing unique solutions, for any need, in the world of building, architecture, interior and exterior decoration and wherever the use of stone and marble products is required.

brembana speed

APPLICATIONS	4-5
BREMBANA SPEED MB TECHNOLOGICAL BENEFITS	6-7
BREMBANA SPEED TR TECHNOLOGICAL BENEFITS	8-9
ACCESSORIES	10-13
SOFTWARE	14-15
DIMENSIONS AND TECHNICAL DATA	16
SPECIAL SOLUTIONS	17
CMS CONNECT	18-19
CMS ACTIVE	20-21
THE RANGE	22-23



APPLICATIONS



countertops | funerary art | sculpting | pools | street furniture | doors, stairs and threshold



architectural and dimensional stonework | inlays and mosaics | fireplaces



BREMBANA SPEED MB

TECHNOLOGICAL BENEFITS

3/4 AXES CNC MACHINE

Brembana speed is a Numerically Controlled Machining Center with three/four interpolated axes suitable for processing both slabs and blocks even with high thickness in marble, granite, composite stone and ceramic.

It can perform each type of raw and polished contouring, as well as milling, drilling, countersinking, bas relief and writing.

This machine can be customized to the customer needs, it is the winning solution for every fabshop.

KEY BUYER BENEFITS

- + **Power at the top of the category:** The electrospindle is CMS technology, liquid-cooled and with power up to 30 kW, which guarantees ideal operating conditions and up to 21% savings on cycle times.
- + **Unrivalled mechanics:** The sturdy structure of the machining center ensures optimal absorption of the stresses derived from machining, guaranteeing a high constant precision over time. The machine base fixed directly to the ground, without the need of building work, increases the stability and performance.
- + **Quality without compromise:** Tool wear control system, which enables the automatic adjustment of the tool position, ensures top quality finishing.
- + **No limits on tool crib thanks to cms solutions:** Up to 120 tools can be installed on the in-line or revolving or under bridge tool rack, which cover all fabshops needs without re-equipping the machine each time.



BREMBANA SPEED TR

TECHNOLOGICAL BENEFITS

3/4 AXES CNC MACHINE WITH ROTATING TABLE (TR)

brembana speed TR is a Numerically Controlled Machining Center with a rotating table and three/four interpolated axes suitable for processing both slabs and blocks even with high thickness in marble, granite, composite stone, and ceramic.

It can perform each type of raw and polished contouring, as well as milling, drilling, countersinking, bas relief, and writing.

Working plane with rotary table allows pendular working mode, resetting downtimes for loading / unloading operations.

This machine can be customized to the customer's needs, it is the winning solution for every fabshop.

KEY BUYER BENEFITS

- + **Power at the top of the category:** The electrospindle is CMS technology, liquid-cooled and with power up to 30 kW, which guarantees ideal operating conditions and up to 21% savings on cycle times.
- + **Unrivalled mechanics:** The sturdy structure of the machining center ensures the optimal absorption of the stresses deriving from machining, guaranteeing a high constant precision over time. The machine base fixed directly to the ground, without the need of building work, increases the stability and performance.
- + **Quality without compromise:** Tool wear control system, which enables the automatic adjustment of the tool position, ensuring top quality finishing.
- + **+43% productivity compared to a standard machine:** The rotary table work plane allows to unload the finished pieces and load new raw pieces while the machine is always in production, eliminating downtime for loading / unloading operations.



ACCESSORIES

Additional rotating axis for NC-controlled turning fixed on the worktop of the machine. Maximum workable dimensions \varnothing 400mm or \varnothing 750 mm, maximum weight 700 Kg.



Thickness probe for the measurement of the true thickness of the stone or ceramic slab to ensure the perfect machining of the workpiece.



Three-step tilting head for the machining of inclined drip trays for kitchen tops. By tilting the working unit, it is possible to perform tilted surface removal in both directions (left and right).

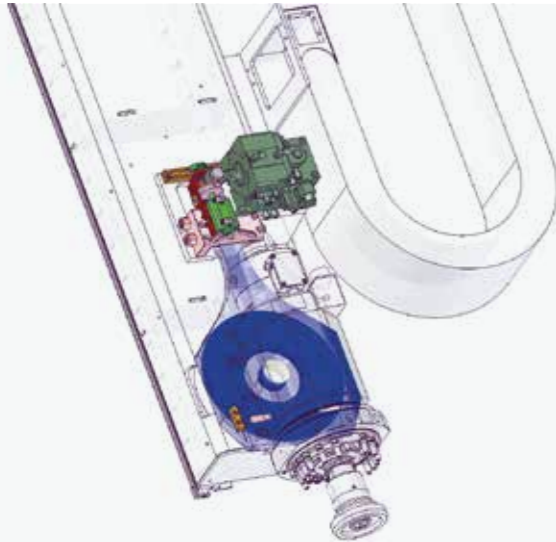

Tool laser presetter for the automatic measuring of tools diameter and/or length; the use of this tool avoids manual setting operations and ensures a better control of tools' wear.

The C rotary Axis (4th axis) allows the use of angular transmissions with their 360° continuous rotation around the Z axis and rapid speed of 9.000°/min.

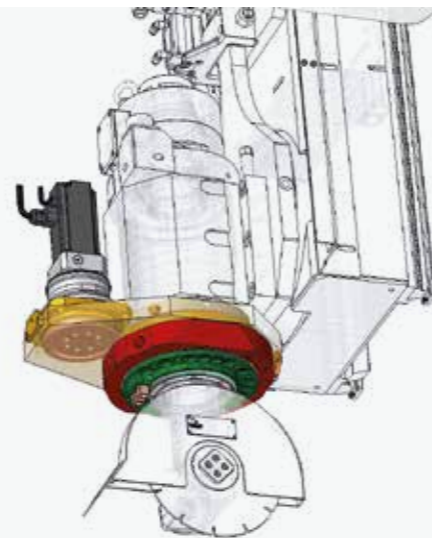

Front recycling tank for working water equipped with metal grate to guarantee to the operator an easy access to the working area



ACCESSORIES

Electrospindle cooling system through chiller unit.



Tool kit for processing and polishing of drainers and sinks with 90° edges.



UNDERBEAM MAGAZINE: 8-station tool magazine housed below the machine beam, usable for grinding wheels, scabble wheels, core drills, inscription and engraving tools for natural stone, composite, and ceramic slabs.



90° saw unit for cutting disks.

90° angular gear for cup wheels.



LASER PROJECTOR FOR SUCTION CUP POSITIONING
The positioning time of the suction cups is significantly reduced due to the laser projector. Thanks to this device it is possible to equip the machine without downtime when working in pendular mode.



BREMBANA SPEED SOFTWARE

EASYSTONE

EasySTONE is a CAD/CAM software package, especially adapted to CMS Stone Technology machining centers and dedicated to the stone industry; it enables 360° management of all CNC-machining related aspects

Available on different levels, it offers the following functions:

- three-dimensional surface design and definition of countertops, extrathick stone sinks, shower trays; shaping and smoothing of custom profiles; inscriptions for the funerary art and decoration; cutting with disks mounted on any kind of angular transmissions
- management of tool table and automatic or manual tool change
- guide to suction cups positioning by an interactive graphics layout
- calculation of machining times and costs
- three-dimensional graphic simulation of the machining process

The above-described functions can be integrated by:

- laser projection of suction cups position or tool-path
- acquisition of thickness variation of the top surface and adjustment of following machining
- measurement and re-setting of tools
- automatic and controlled management of polishing pressures
- acquisition of templates by laser beamers
- SMS messaging for remote interfacing with the machining center

It is also possible to import complex copied/defined surfaces via external equipment and CADs, or acquiring complex surfaces, like bas-reliefs or sculptures, via laser copiers.

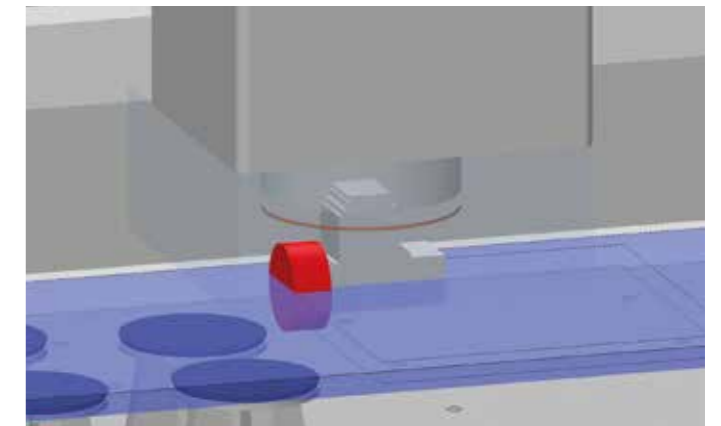
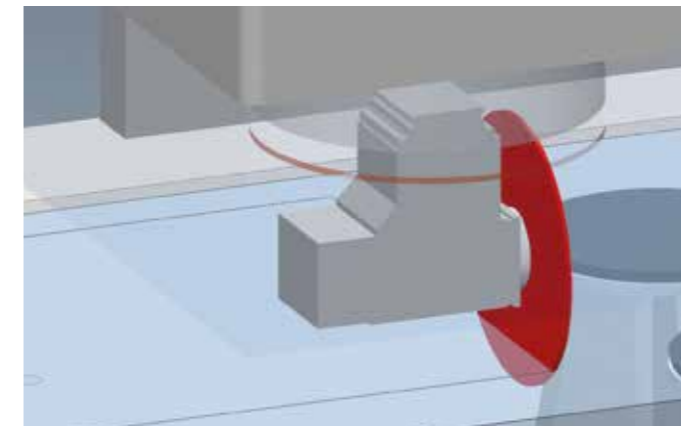
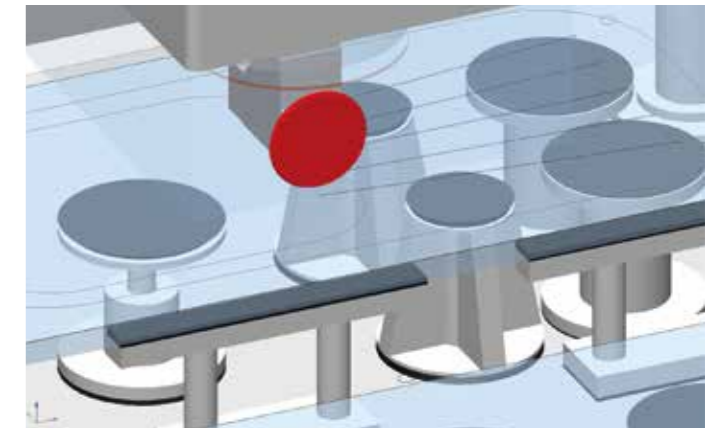
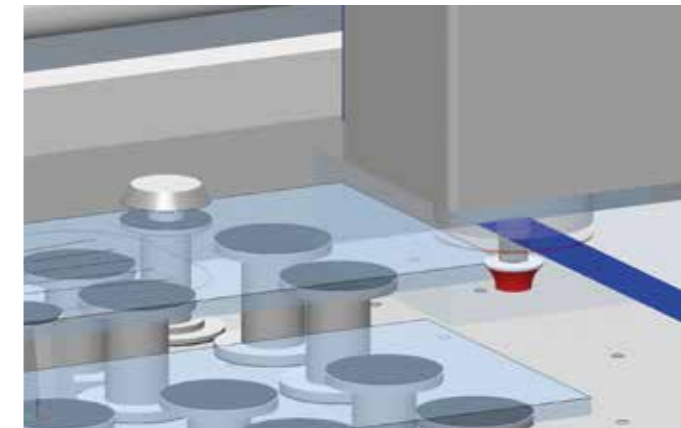
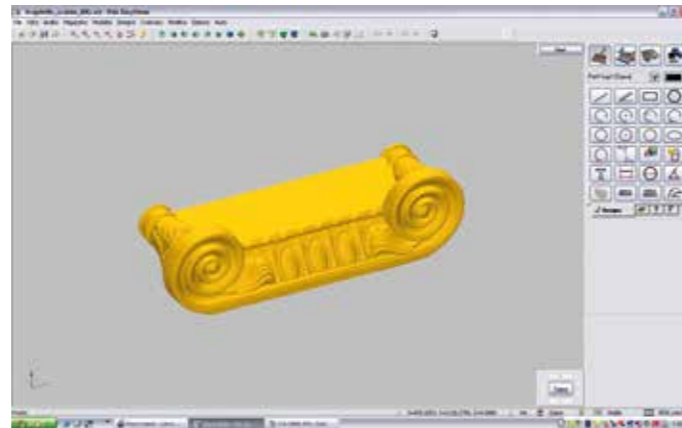
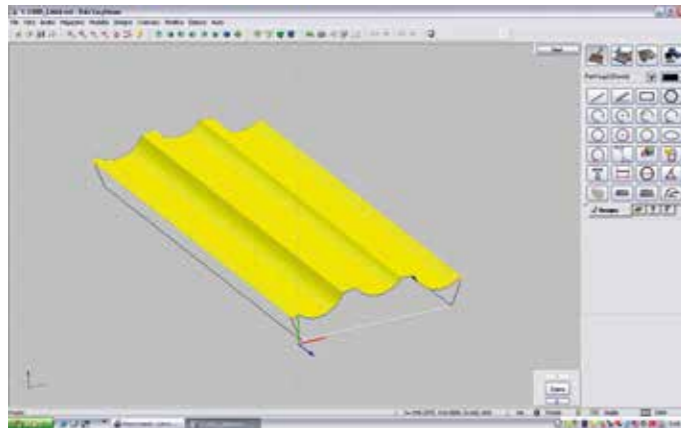
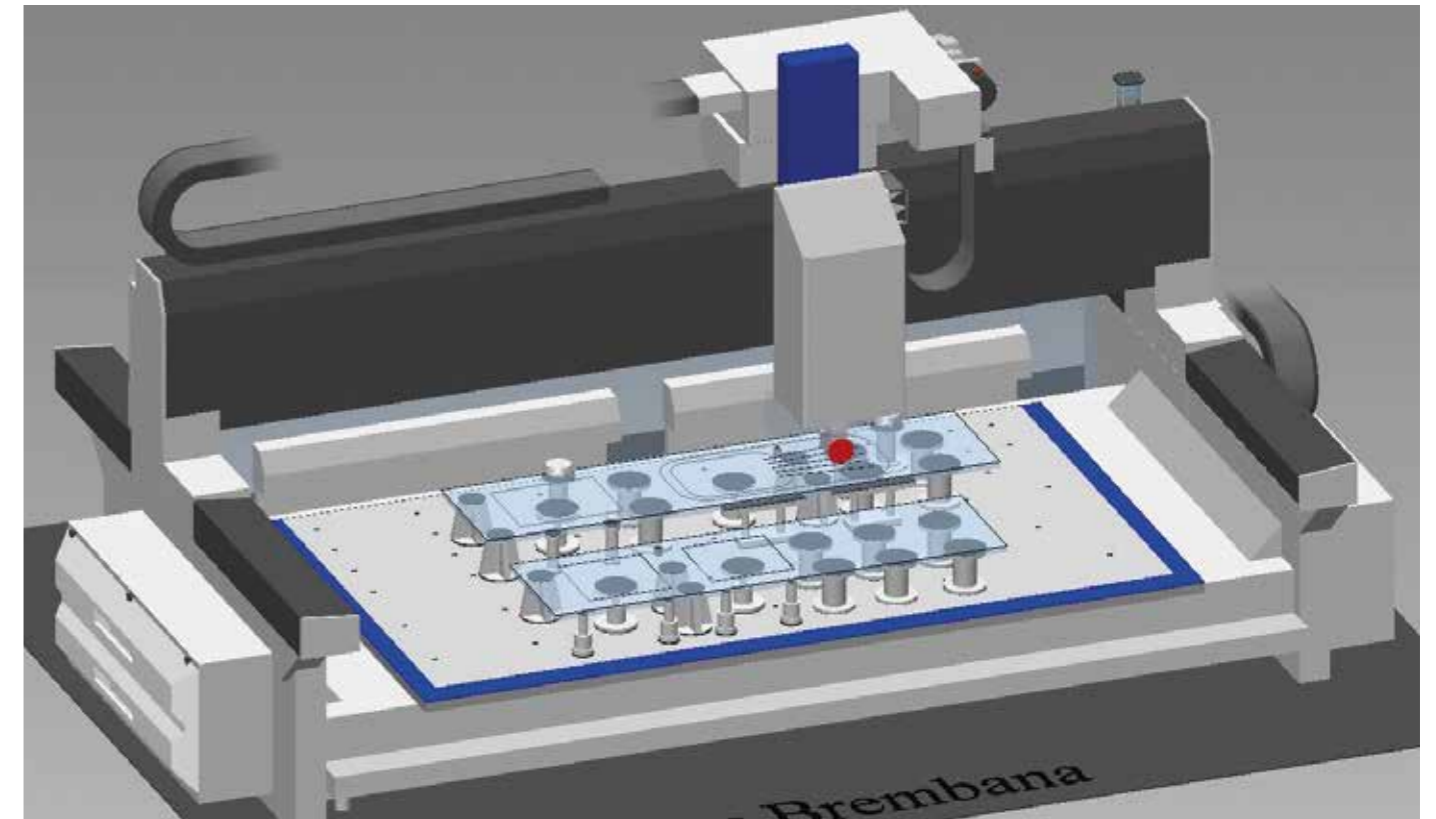

BREMBANA SPEED

DIMENSIONS AND TECHNICAL DATA

BREMBANA SPEED MB (MONOBLOCK): TECHNICAL DATA		
X AXES STROKE	2800 ÷ 3800 mm / 110 ÷ 149 in	
Y AXES STROKE	1650 ÷ 7200 mm / 65 ÷ 283 in	
Z AXES STROKE	350 ÷ 900 mm / 14 ÷ 35 in	
ROTATING AXIS	C = 360° stepless	
NO. STATIONS TOOL CHANGER	12 ÷ 120	
ELECTROSPINDLE POWER	13,5 KW / 18 HP	30 KW / 40 HP
REVLUTION	0 ÷ 15000 rpm	0 ÷ 12000 rpm
CONNECTION	ISO 40	ISO 40
TORQUE	22 Nm a 6000 rpm	39 Nm a 6000 rpm
ELECTRICAL CABINET	integrated in the base	
WEIGHT	4300 ÷ 15000 Kg	

BREMBANA SPEED TR (ROTATING TABLE): TECHNICAL DATA		
X AXES STROKE	3800 ÷ 4250 mm / 150 ÷ 167 in	
Y AXES STROKE	2610 ÷ 4550 mm / 103 ÷ 179 in	
Z AXES STROKE	420 ÷ 900 mm / 16 ÷ 35 in	
ROTATING AXIS	C = 360° stepless	
NO. STATIONS TOOL CHANGER	26 ÷ 120	
ELECTROSPINDLE POWER	13,5 KW / 18 HP	30 KW / 40 HP
REVLUTION	0 ÷ 15000 rpm	0 ÷ 12000 rpm
CONNECTION	ISO 40	ISO 40
TORQUE	22 Nm a 6000 rpm	39 Nm a 6000 rpm
ELECTRICAL CABINET	integrated in the base	
WEIGHT	8900 ÷ 10800 kg	

SPECIAL SOLUTIONS

BREMBANA SPEED OF

3/4 axes CNC machine with masonry or steelwork separate-supports (Open Frame).

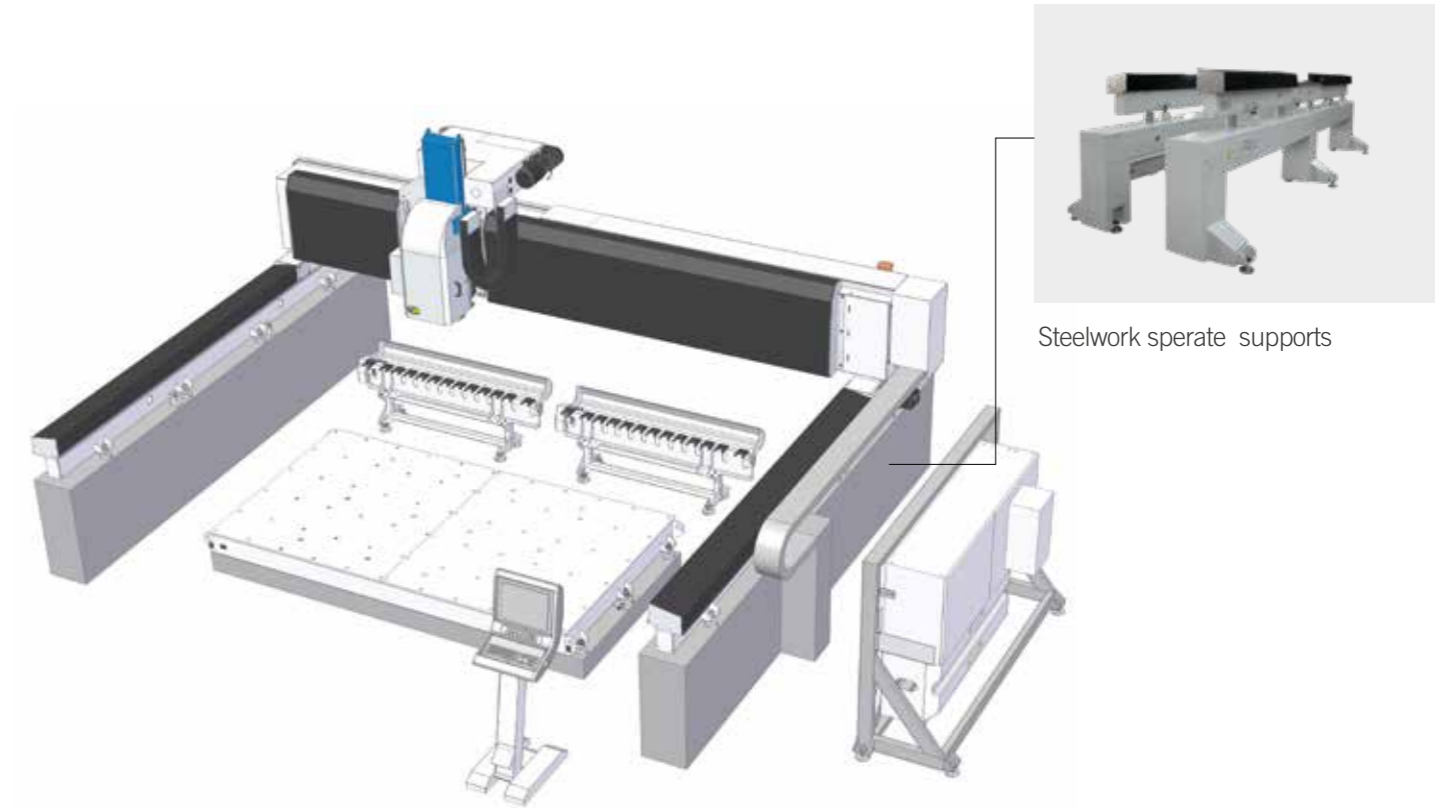

BREMBANA SPEED OF

3/4 axes CNC machine with double worktable and separate-supports for working in alternating mode.

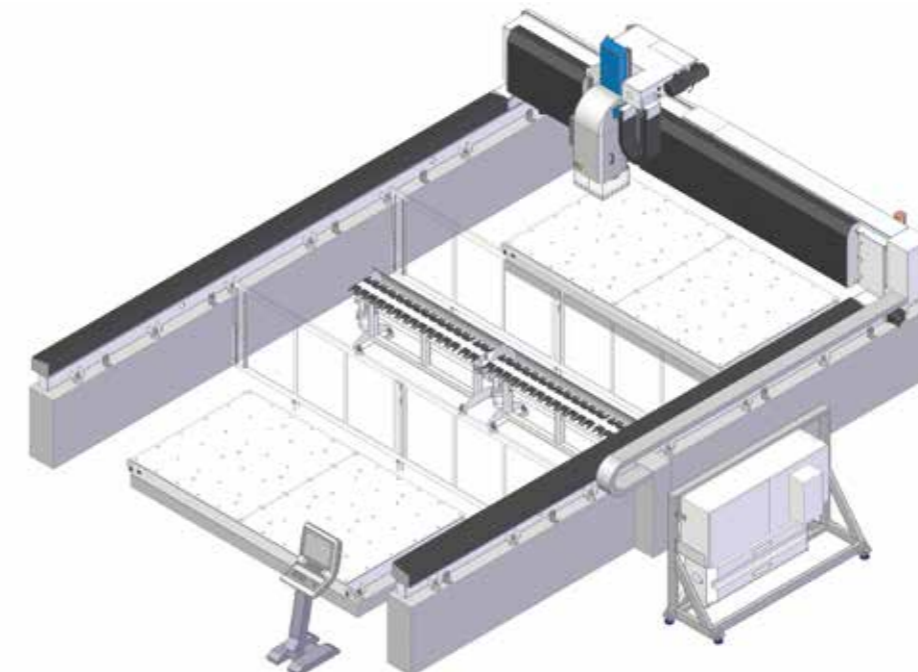

CMS connect the IoT platform perfectly integrated with the latest-generation CMS machines

CMS Connect is able to offer customised micro services through the use of IoT Apps that support the daily activities of industry operators - improving the availability and use of machines or systems. The platform displays, analyses and monitors all data from connected machines. The data collected by the machines in real time become useful information increase machine productivity, reduce operating and maintenance costs and cut energy costs.

APPLICATIONS

SMART MACHINE: Section designed for the continuous monitoring of machine operation, with information on:

Status: machine status overviews. The representations provided allow machine availability to be checked - to identify possible bottlenecks in the production flow.

Monitoring: instantaneous, live display of the operation of the machine and its components, of currently running programs and potentiometers;

Production: list of machine programs run within a given timeframe with best time and average running time;

Alarms: active and historical warnings.

SMART MAINTENANCE

This section provides a first approach to predictive maintenance by sending notifications when machine components indicate a potentially critical state associated with reaching a certain threshold. In this way, it is possible to take action and schedule maintenance services, without any down-time.

SMART MANAGEMENT

Section designed for KPI presentation for all the machines connected to the platform.

The indicators provided assess of the availability, productivity and efficiency of the machine and the quality of the product.

MAXIMISED SECURITY

CMS Connect uses the standard OPC-UA communication protocol, which guarantees the encryption of data at Edge interface level. CMS Connect's Cloud and DataLake levels meet all state-of-the-art cyber-security requirements. Customer data are encrypted and authenticated to ensure total protection of sensitive information.

ADVANTAGES

- ✓ Optimisation of production performance
- ✓ Diagnostics to support components warranty optimisation
- ✓ Productivity increase and downtime reduction
- ✓ Improvement of quality control
- ✓ Maintenance costs down



CMS active CMS active a revolutionary interaction with your cms machine

Cms active is our new interface. The same operator can easily control different machines as the “CMS Active interfaces maintain the same look&feel, icons and iteration approach.

EASY OF USE

The new interface has been especially developed and optimized to be immediately used via touch screen. Graphics and icons have been redesigned for user-friendly and comfortable navigation.

ADVANCED ORGANIZATION OF PRODUCTION

Cms Active enables configuring different users with different roles and responsibilities according to the operation mode of the machining center (e.g.: operator, maintenance man, administrator, ...).

It is also possible to define the work shifts on the machining center and then survey activities, productivity and events that have occurred in each shift.

ABSOLUTE QUALITY OF THE FINISHED WORKPIECE

With CMS aActive the quality of the finished workpiece is no longer jeopardized by worn-out tools. The new Tool Life Determination system of CMS Active sends warning messages when the tool life is running out and recommends its replacement at the most appropriate time.

TOOL SET-UP? NO PROBLEM!

CMS Active guides the operator during the tool magazine set-up phase, also allowing for the programs to be run.



THE RANGE OF CMS STONE TECHNOLOGY

FOR STONE PROCESSING

3/4 AXES CNC MACHINES AND 5/6 AXES CNC MACHINES



BREMBANA SPEED



BREMBANA SPEED TR



BREMBANA MAXIMA



BREMBANA G-REX

5 AXES BRIDGE SAWS AND 5 AXES SAW JET MACHINES

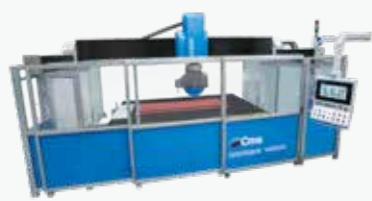

BREMBANA VENKON



BREMBANA KOSMOS



BREMBANA IMPACT



BREMBANA FORMAX

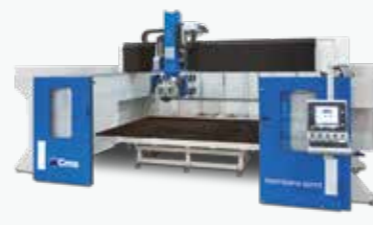

BREMBANA SPRINT



BREMBANA GIXA



BREMBANA FORMAX JET / SPRINT JET

WATERJET CUTTING MACHINES AND PRESSURE INTENSIFIERS

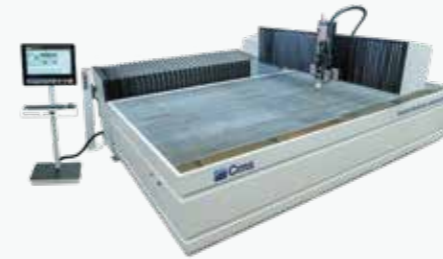

BREMBANA EASYLINE



BREMBANA SMARTLINE



BREMBANA MILESTONE S



BREMBANA IDROLINE S



BREMBANA AQUATEC



BREMBANA EASYPUMP



BREMBANA JET POWER EVO



BREMBANA GREENJET EVO



C.M.S. SPA
via A. Locatelli, 123 - 24019 Zogno (BG) - IT
Tel. +39 0345 64111
info@cms.it
cms.it

a company of **scm**group